

MITSUBISHI ELECTRIC

GT16 RGB Output Unit

User's Manual

GT16M-ROUT

Thank you for purchasing the GOT1000 Series.

Prior to use, please read both this manual and detailed manual thoroughly to fully understand the product.

MODEL	GT16M-ROUT-U
MODEL CODE	1D7M86
IB(NA)-0800430-G(1610)MEE	

GRAPHIC OPERATION TERMINAL

GOT1000

SAFETY PRECAUTIONS

(Always read these precautions before using this equipment.)

Before using this product, please read this manual and the relevant manuals introduced in this manual carefully and pay full attention to safety to handle the product correctly. The precautions given in this manual are concerned with this product.

In this manual, the safety precautions are ranked as "DANGER" and "CAUTION".

DANGER Indicates that incorrect handling may cause hazardous conditions, resulting in death or severe injury.

CAUTION Indicates that incorrect handling may cause hazardous conditions, resulting in medium or slight personal injury or physical damage.

Note that the CAUTION level may lead to a serious accident according to the circumstances. Always follow the precautions of both levels because they are important to personal safety. Please save this manual to make it accessible when required and always forward it to the end user.

DESIGN PRECAUTIONS

CAUTION

- Do not bunch the control wires or communication cables with the main circuit or power wires, or lay them close to each other. As a guide, separate the lines by a distance of at least 100mm (3.94 inches) otherwise malfunctions may occur due to noise.

INSTALLATION PRECAUTIONS

DANGER

- Be sure to shut off all phases of the external power supply used by the system before mounting or removing this unit to/from the GOT. Not doing so can cause a unit failure or malfunction.
- Before connecting the Bus connection cable to this unit, always shut off GOT power and PLC CPU power externally in all phases. Not doing so can cause a malfunction.

CAUTION

- Use this unit in the environment that satisfies the general specifications described in the User's Manual for the GOT used. Not doing so can cause an electric shock, fire, malfunction or product damage or deterioration.
- Do not drop the unit or subject it to string shock. A unit damage may result.
- When installing this unit to the GOT, fit it to the connection interface of the GOT and tighten the mounting screws in the specified torque range. Undertightening can cause a drop, failure or malfunction. Overtightening can cause a drop, failure or malfunction due to screw or unit damage.

WIRING PRECAUTIONS

DANGER

- Be sure to shut off all phases of the external power supply used by the system before wiring. Failure to do so may result in an electric shock, product damage or malfunctions.

CAUTION

- Exercise care to avoid foreign matter such as chips and wire offcuts entering the unit. Not doing so can cause a fire, failure or malfunction.
- Make sure to securely connect the cable to the connector of unit. Incorrect connection may cause malfunctions.

STARTUP AND MAINTENANCE PRECAUTIONS

DANGER

- Before starting cleaning, always shut off GOT power externally in all phases. Not doing so can cause a unit failure or malfunction. Undertightening can cause the GOT to drop, short circuit or malfunction. Overtightening can cause a short circuit or malfunction due to the damage of the screws or unit.
- Do not disassemble or modify any unit. This will cause failure, malfunction, injuries, or fire.
- Do not touch the conductive areas and electronic parts of this unit directly. Doing so can cause a unit malfunction or failure.

CAUTION

- Always secure the cables connected to the unit, e.g. run them in conduits or clamp them. Not doing so can cause unit or cable damage due to dangling, moved or accidentally pulled cables or can cause a malfunction due to a cable contact fault.
- Do not hold the cable part when unplugging any cable connected to the unit. Doing so can cause unit or cable damage or a malfunction due to a cable contact fault.
- Always make sure to touch the grounded metal to discharge the electricity charged in the body, etc., before touching the unit. Failure to do so may cause a failure or malfunctions of the unit.

DISPOSAL PRECAUTIONS

CAUTION

- Dispose of this product as industrial waste.

TRANSPORTATION PRECAUTIONS

CAUTION

- Make sure to transport the GOT main unit and/or relevant unit(s) in the manner they will not be exposed to the impact exceeding the impact resistance described in the general specifications of the User's Manual for the GOT used, as they are precision devices. Failure to do so may cause the unit to fail. Check if the unit operates correctly after transportation.

Manual

The following shows manuals relevant to this product.

Detailed Manual

Manual name	Manual number (Model code)
GT16 User's Manual (Hardware) (Sold separately)	SH-080928ENG (1D7MD3)
GOT1000 Series Connection Manual (Microcomputer, MODBUS Products, Peripherals) for GT Works3 (Sold separately)	SH-080871ENG (1D7MC5)
GT Designer3 Version1 Screen Design Manual (Functions) (Sold separately)	SH-080867ENG (1D7MC1)

Relevant Manuals

For relevant manuals, refer to the PDF manuals stored in the DVD-ROM for the drawing software used.

© 2008 MITSUBISHI ELECTRIC CORPORATION

Compliance with the EMC and Low Voltage Directives

To configure a system meeting the requirements of the EMC and Low Voltage Directives when incorporating the Mitsubishi GOT (EMC and Low Voltage Directives compliant) into other machinery or equipment, refer to "EMC AND LOW VOLTAGE DIRECTIVES" of the General Description included with the GOT used. The CE mark, indicating compliance with the EMC and Low Voltage Directives, is printed on the rating plate of the GOT.

Compliance with the Radio Waves Act (South Korea)

This product complies with the Radio Waves Act (South Korea). Note the following when using the product in South Korea.

이 기기는 업무용 (A급) 전자파적합기기로서 판매자 또는 사용자는 이 점을 주의하시기 바랍니다. 기경외의 지역에서 사용하는 것을 목적으로 합니다. (The product is for business use (Class A) and meets the electromagnetic compatibility requirements. The seller and the user must note the above point, and use the product in a place except for home.)

Compliance with the new China RoHS directive

GOT 相关的基于“电器电子产品有害物质限制使用管理办法”要求的表示方法



Note: This symbol mark is for China only.

含有有害6物质的名称、含量、含有部件
本产品中所含有的有害6物质的名称、含量、含有部件如下表所示。
产品中有害物质的名称及含量

部件名称	有害物质					
	铅 (Pb)	汞 (Hg)	镉 (Cd)	六价铬 (Cr(VI))	多溴联苯 (PBB)	多溴二苯醚 (PBDE)
电路板组件	×	○	○	○	○	○
树脂壳体、电缆、线材	○	○	○	○	○	○
钣金部件、螺钉等金属部件	○	○	○	○	○	○

本表格依据 SJ/T11364 的规定编制。
○：表示该有害物质在该部件所有均质材料中的含量符合 GB/T26572 规定的限量要求。
×：表示该有害物质至少在该部件的某一均质材料中的含量超出 GB/T26572 规定的限量要求。

Packing List

After unpacking the box, check that the following products are included.

Model	Product	Quantity
GT16M-ROUT	RGB output unit	1
	Mounting screw set (4 screws, 4 stickers)	1
	Extension interface relay board	1
	GT16 RGB Output Unit User's Manual (This manual)	1

1. OVERVIEW

This User's Manual describes the GT16M-ROUT RGB output unit (hereinafter referred to as the RGB output unit). When mounting RGB output unit with GT16□□ M the RGB output unit can external display screens on GOT.

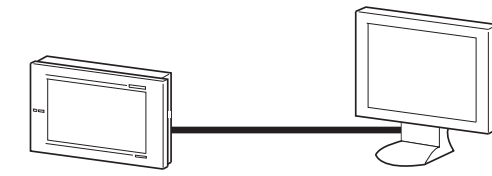

GOT+GT16M-ROUT External display
To use the RGB output unit set the communication settings. For the settings and system configurations, refer to GOT1000 Series Connection Manual. For RGB output functions, refer to GT Designer2 Version□ Screen Design Manual.

2. SPECIFICATIONS

The following shows the performance specifications of the the RGB output unit.

The general specifications of the RGB output unit are the same as those of the GOT.

For the general specifications of the GOT, refer to the User's Manual for the GOT used.

2.1 RGB output unit

Item	Specifications		
	GT1695M-X	GT1685M-S GT1675M-S GT1665M-S	GT1675M-S GT1665M-S
RGB output format	Analog RGB		
Display size (dot)	XGA; 1024 x 768	SVGA; 800 x 600	VGA; 640 x 480
Number of RGB output channels	1 channel		
Dot clock	65.000 MHz	40.000 MHz	25.175 MHz
Horizontal scanning frequency	48.4 kHz	37.9 kHz	31.5 kHz
Vertical scanning frequency	60 Hz		
Timing chart	Refer to 2.2.	Refer to 2.3.	Refer to 2.4.
Connector for external connection	D-Sub15 pin: female		
Internal current consumption	3.3VDC	0.13A	
	5.0VDC	0.11 A	
Weight	0.17 kg (0.34 lb)		

2.2 GT1695M-X Timing Chart

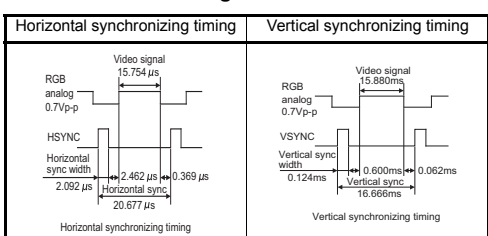

2.3 GT1685M-S, GT1675M-S, and GT1665M-S Timing Chart

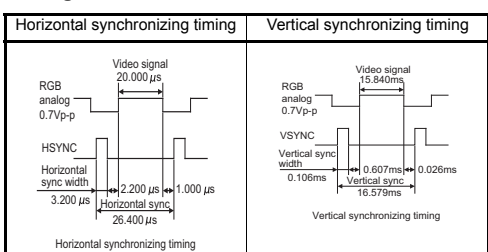

2.4 GT1675M-V and GT1665M-V Timing Chart

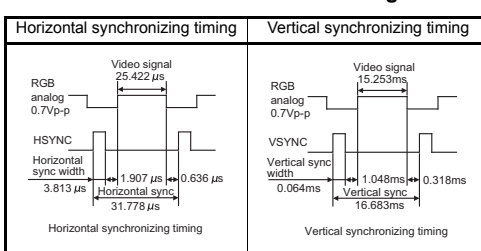

3. PART NAMES AND EXTERNAL DIMENSIONS

3.1 RGB Output Unit

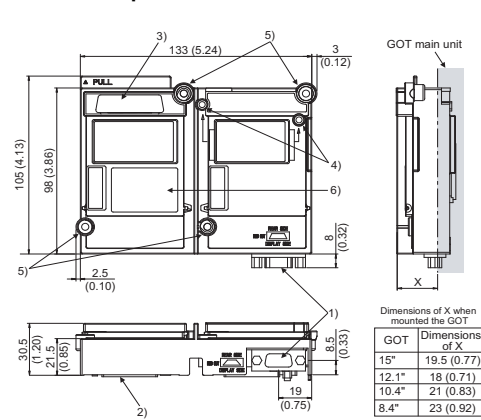

No.	Name	Description
1)	Connector for RGB output	Connector for connecting a 9-core combined cable
2)	Interface connector	Connector connected to the GOT
3)	Extension connector	Connector for connecting an extension unit
4)	Board fixing screw	Screw for fixing the extension interface relay board
5)	Mounting screw	Screw for fixing the RGB output unit
6)	Rating plate	-

3.2 Extension Interface Relay Board

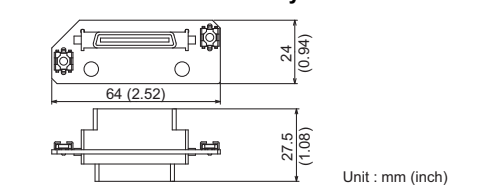

4. INSTALLATION PROCEDURE

The installation procedure for the RGB output unit is explained using the GT1675.

- Turn off the GOT.
- Remove two extension unit covers of the GOT.
- Connect the extension interface relay board to the extend I/F-2 on the GOT. Remove the connector cover from the board.
- Fit the RGB output unit in the GOT case.
- Tighten four mounting screws with a torque of 0.36 to 0.48 N·m to fix the unit.
- Tighten two board fixing screws with a torque of 0.36 to 0.48 N·m to fix the board.
- For mounting any extension unit on the RGB output unit, remove the connector cover and the stickers. For mounting no extension unit on the RGB output unit, cover over four mounting screws with the accessory stickers to avoid static electricity.

Keep the connector cover fixed. Keep all the stickers fixed.

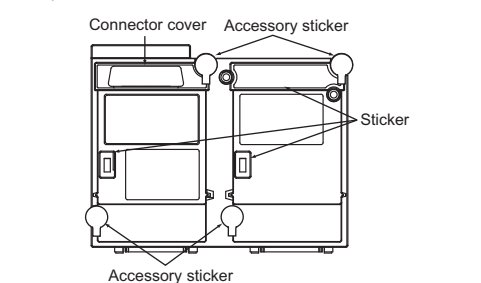

Point
Remove the screws that fixes the extension interface relay board before removing the unit.(Above 6))

Warranty

Mitsubishi will not be held liable for damage caused by factors found not to be the cause of Mitsubishi; machine damage or lost profits caused by faults in the Mitsubishi products; damage, secondary damage, accident compensation caused by special factors unpredictable by Mitsubishi; damages to products other than Mitsubishi products; and to other duties.

For safe use

- This product has been manufactured as a general-purpose part for general industries, and has not been designed or manufactured to be incorporated in a device or system used in purposes related to human life.
- Before using the product for special purposes such as nuclear power, electric power, aerospace, medicine or passenger movement vehicles, consult with Mitsubishi.
- This product has been manufactured under strict quality control. However, when installing the product where major accidents or losses could occur if the product fails, install appropriate backup or failsafe functions in the system.

Country/Region	Sales office/Tel
USA	Mitsubishi Electric Automation, Inc. 500 Corporate Woods Parkway, Vernon Hills, IL 60061, U.S.A. Tel: +1-847-478-2100
Brazil	Mitsubishi Electric do Brasil Comercio e Servicos Ltda. Rua Jussara, 1750- Bloco B Anexo, Jardim Santa Cecilia, CEP 06465-070, Barueri - SP, Brazil Tel: +55-11-4899-3000
Mexico	Mitsubishi Electric Automation, Inc. Mexico Branch Mariano Escobedo #99, Col. Zona Industrial, Tlalnepantla Edo. Mexico, C.P.54030 Tel: +52-55-3067-7511
Germany	Mitsubishi Electric Europe B.V. German Branch Mitsubishi-Electric-Platz 1, 40882 Ratingen, Germany Tel: +49-2102-466-0
UK	Mitsubishi Electric Europe B.V. UK Branch Travellers Lane, Hatfield, Hertfordshire, AL10 8XB, U.K. Tel: +44-1707-26-8780
Italy	Mitsubishi Electric Europe B.V. Italian Branch Centro Direzionale Colleoni - Palazzo Sirio, Viale Colleoni 7, 20864 Agrate Brianza (Milano), Italy Tel: +39-039-60531
Spain	Mitsubishi Electric Europe B.V. Spanish Branch Carretera de Rubi 76-80- Apdo.420, 08190 Sant Cugat del Valles (Barcelona), Spain Tel: +34-93-65-65-131
France	Mitsubishi Electric Europe B.V. French Branch 25, Boulevard des Bouvets, 92741 Nanterre Cedex, France Tel: +33-1-55-68-55-88
Czech	Mitsubishi Electric Europe B.V. Czech Branch Avenir Business Park, Radlicka 751/113e, 158 00 Praha 5, Czech Republic Tel: +420-251-651-170
Turkey	Mitsubishi Electric Turkey A.S. Umraniye Branch Serfali Mahallesi Nispetiye Sokak No:5, TR-34775 Umraniye / Istanbul, Turkey Tel: +90-216-526-9990
Poland	Mitsubishi Electric Europe B.V. Polish Branch ul. Krakowska 50, 32-083 Balice, Poland Tel: +48-12-347-65-00
Russia	Mitsubishi Electric (Russia) LLC St. Petersburg Branch Piskarevsky pr. 2, bld 2, lit "Sch", BC "Bernua", office 720; RU-195027 St. Petersburg, Russia Tel: +7-812-633-3497
South Africa	Adroit Technologies 20 Waterford Office Park, 189 Wilkoppen Road, Fourways, Johannesburg, South Africa Tel: +27-11-658-8100
China	Mitsubishi Electric Automation (China) Ltd. No.1386 Hongqiao Road, Mitsubishi Electric Automation Center, Shanghai, China Tel: +86-21-2322-9030
Taiwan	SETSUYO ENTERPRISE CO., LTD. 6F, No.105, Wugong 3rd Road, Wugu District, New Taipei City 24889, Taiwan Tel: +886-2-2299-2489
Korea	Mitsubishi Electric Automation Korea Co., Ltd. 7F-9F, Gangseo Hangang Xi-tower A, 401, Yangcheon Gangseo-Gu, Seoul 07526, Korea Tel: +82-2-3660-9530
Singapore	Mitsubishi Electric Asia Pte. Ltd. 307 Alexandra Road, Mitsubishi Electric Building, Singapore 159943 Tel: +65-6473-2308
Thailand	Mitsubishi Electric Factory Automation (Thailand) Co., Ltd. 12th Floor, SIV City Building, Office Tower 1, No. 898/19 and 20 Rama 3 Road, Kwang Bangpangpang, Khet Yamaawa, Bangkok 10120, Thailand Tel: +66-2682-6522 to 31
Indonesia	PT. Mitsubishi Electric Indonesia Gedung Jaya 11th Floor, Jl. MH. Thamrin No.12, Jakarta Pusat 10340, Indonesia Tel: +62-21-3192-6461
Vietnam	Mitsubishi Electric Vietnam Co., LTD. Ho Chi Minh Head Office Unit 01-04, 10th Floor, Vincom Center, 72 Le Thanh Ton Street, District 1, Ho Chi Minh City, Vietnam Tel: +84-9-3910-5945
India	Mitsubishi Electric India Pvt. Ltd. Pune Branch Emerald House, EL-3, J Block, M.I.D.C., Bhosari, Pune - 411026, Maharashtra, India Tel: +91-20-2710-2000
Australia	Mitsubishi Electric Australia Pty. Ltd. 348 Victoria Road, P.O. Box 11, Rydalmere, N.S.W. 2116, Australia Tel: +61-2-9684-7777

MITSUBISHI ELECTRIC CORPORATION
HEAD OFFICE: TOKYO BUILDING, 2-7-3 MARUNOUCHI, CHYODA-KU, TOKYO 100-8310, JAPAN
NAGOYA WORKS: 1-14, YADA-MINAMI 5-CHOME, HIGASHI-KU, NAGOYA, JAPAN

When exported from Japan, this manual does not require application to the Ministry of Economy, Trade and Industry for service transaction permission.
Specifications subject to change without notice.
Printed in Japan, October 2016.